

Plumbing · HVAC · Electrical

Top Shelf.

The Ultimate Shelving and Inventory System from Hackney

Fast Facts:

The Only Complete System

Pipe and Ladder
Storage Inside

All Aluminum

Open Space for Water Heaters

Infinitely Adjustable

Flexible Storage
Accommodates Large
Equipment

Custom Designed
for Tray Storage
Inventory

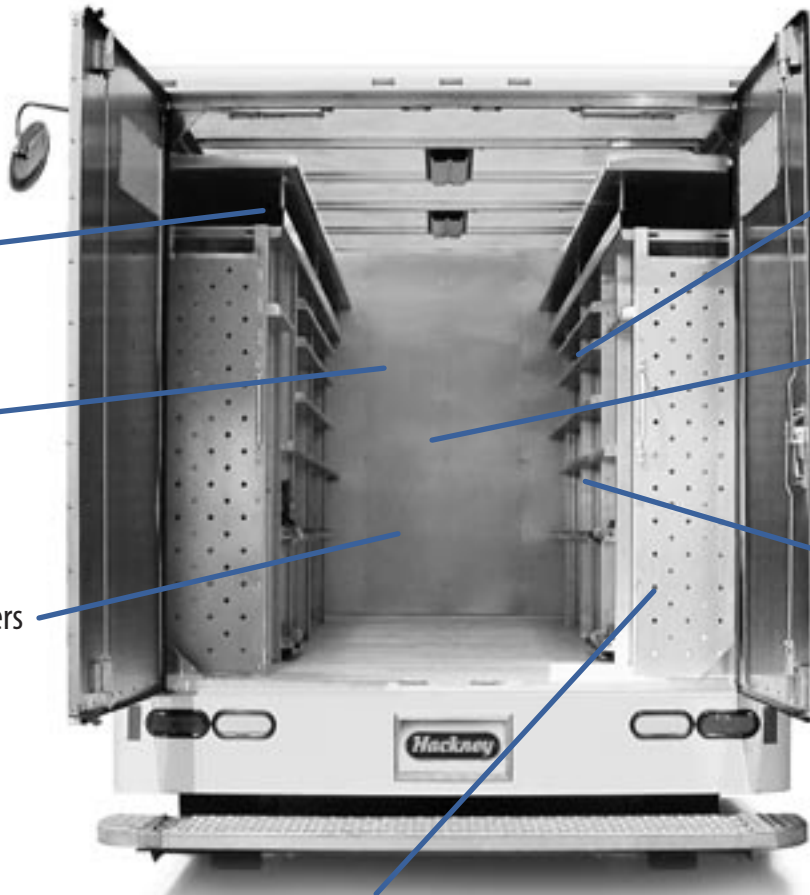

Perforated End Panels

Shelves shown installed in the complete Hackney AC1000 body.
Now available as a complete system or for retrofit



Hackney: the smart choice

Whether you need a shelving system upgrade and retrofit or a complete system including a full truck body, Hackney is the smart choice.

Plumbing

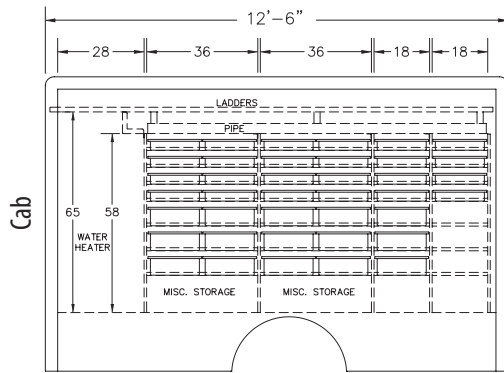

Driver's Side 12'

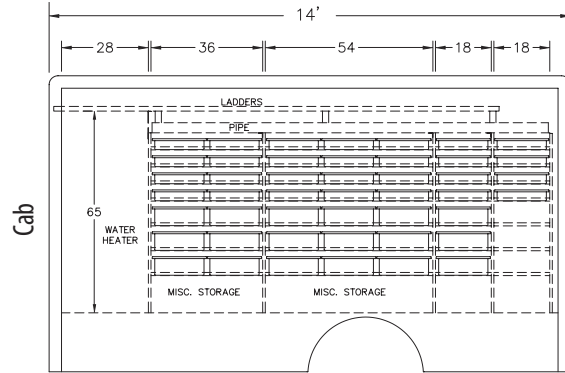

Driver's Side 14'

HVAC

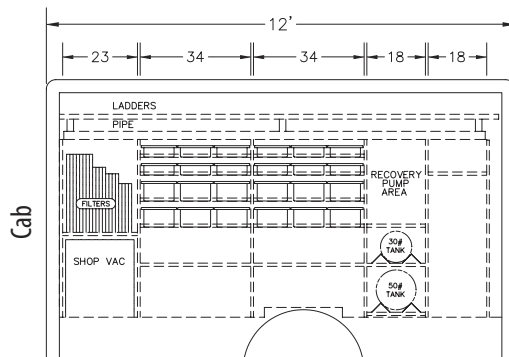

Driver's Side

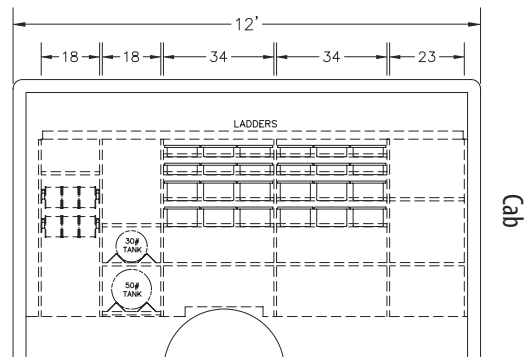

Curbside

Electrical

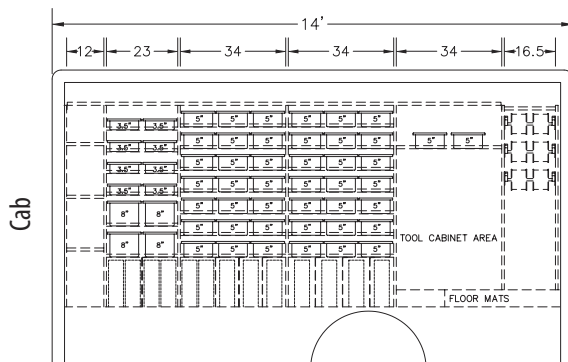

Driver's Side

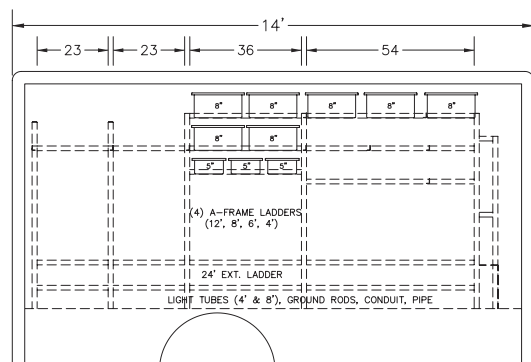

Curbside



VT Specialized Vehicles Corporation

A company of Vision Technologies Systems

Hackney • 400 Hackney Avenue • Washington, NC 27889

Hackney Special Applications Vehicles • Hackney Parts

1-800-763-0700 • 1-877-238-7278 • Worldwide: USA-252-946-6521

www.hackneyparts.com • www.hackneyusa.com • www.hackneyservice.com

Options & Accessories

Customize the ultimate shelving systems to fit your needs exactly.

PLUMBING

Set of 78 HD Plastic Storage Trays – for 12 ft. shelf kit

- 30 Tall – 6" H x 17.5" W x 22.38" L
- 48 Short – 3.5" H x 17.5" W x 22.38" L
- Adjustable Dividers for 9 compartments each tray
- 78 Snap-on Label Holders

Set of 92 HD Plastic Storage Trays – for 14 ft. shelf kit

- 36 Tall – 6" H x 17.5" W x 22.38" L
- 56 Short – 3.5" H x 17.5" W x 22.38" L
- Adjustable Dividers for 9 compartments each tray
- 92 Snap-on Label Holders

- Single Trays – available in both sizes with dividers & label holders
- Single Adjustable Shelves – available in 18", 36", & 54" widths
- (2) Perforated Tool Hanging Panels – vertical surface of rear shelf sections

HVAC

Set of 48 MD Plastic Storage Trays

- 24 Tall – 6" H x 11" W x 16.5" L – adj. dividers for 6 comp. each tray
- 24 Short – 3.5" H x 11" W x 16.5" L – adj. dividers for 8 comp. each tray
- 48 Snap-on Label Holders

- Single Trays – available in both sizes with dividers & label holders
- Single Adjustable Shelves – available in 18", 23", & 34" widths
- Freon Shelf – 18" W adjustable – accommodates 30# or 50# tanks
- Ladder Shelf for Curbside
- (2) Perforated Tool Hanging Panels – vertical surface of rear shelf sections
- Wire Spool Holder – 18" W adjustable with 2 bars – holds 4-6 spools

ELECTRICAL

Set of 66 MD Plastic Storage Trays

- (7) 8" H x 17" W x 22" L – includes 3 Long + 12 Short dividers
- (4) 8" H x 11" W x 16.5" L – includes 4 Long + 4 Short dividers
- (47) 5" H x 11" W x 16.5" L – includes 72 Long + 120 Short dividers
- (8) 3.5" H x 11" W x 16.5" L – includes 8 Long + 36 Short dividers
- 66 Snap-on Label Holders

- Single Trays – available in all sizes with dividers and label holders
- Single Adjustable Shelves Drivers Side – available in 12", 23", & 34" widths
- Single Wire Spool Holder – 16.5" W adjustable with 2 bars
holds 4-6 spools

HD Plastic Trays- Plumbing-Tall and Short



MD Plastic Trays- HVAC-Tall and Short



No photo-MD Plastic Trays- Electrical-Multiple sizes

Don't see what you need? Call Hackney!
We have a variety of options to tailor a unit for your operation.

Hackney

Plumbing

A Plumb Perfect Package

Hackney knows plumbing. And plumbers know the ideal shelving systems for their work vehicles.

Here is the only shelving system available that is mounted on tracks to adjust to fit your needs exactly. The Hackney system makes it easy to store ladders and pipe safely, plus the open-end spaces easily accommodate water heaters and bulky items.

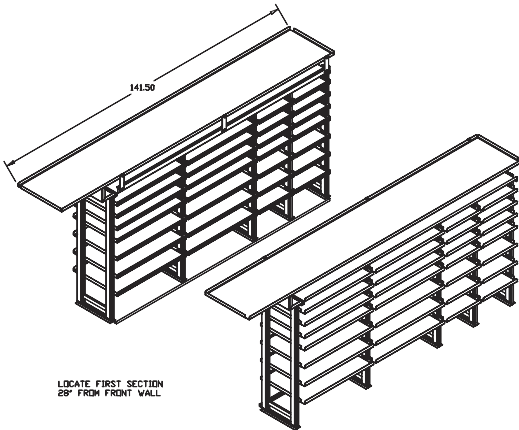

SHELVES (12 ft. body)

- (28) 36" W – adj.
- (28) 18" W – adj.
- (2) 123" W – pipe
- (2) 141" W – ladders
- (2) 110" L – floor angles

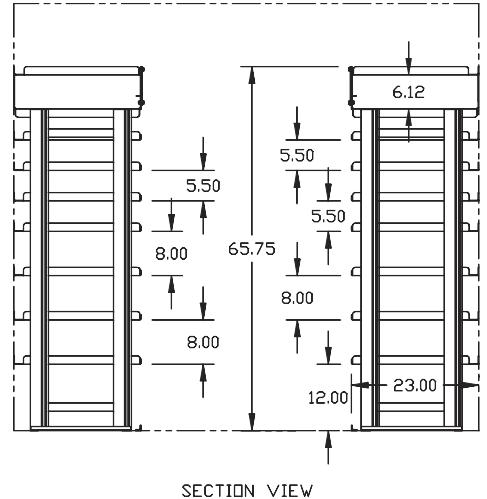

SHELVES (14 ft. body)

- (14) 36" W – adj.
- (14) 54" W – adj.
- (28) 18" W – adj.
- (2) 131" W – pipe
- (2) 141" W – ladders
- (2) 128" L – floor angles

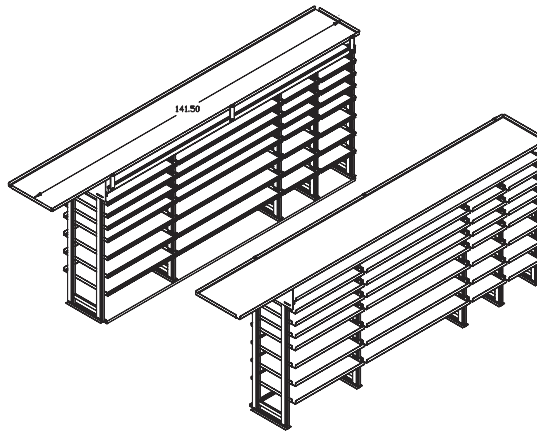

Hackney

Heating and Air Conditioning

HVAC Efficiency Enhancer

Deep experience with the HVAC trade provides Hackney the know-how to create the most efficient shelving and inventory systems. These shelves are built leaving a wide aisle—allowing room for bulky items like air conditioning units. Top shelves provide lockable storage for two extension ladders or a combination of longer PVC conduit and ladders. Freon tanks and filters fit in perfectly. This shelving is customer-built for HVAC professionals.

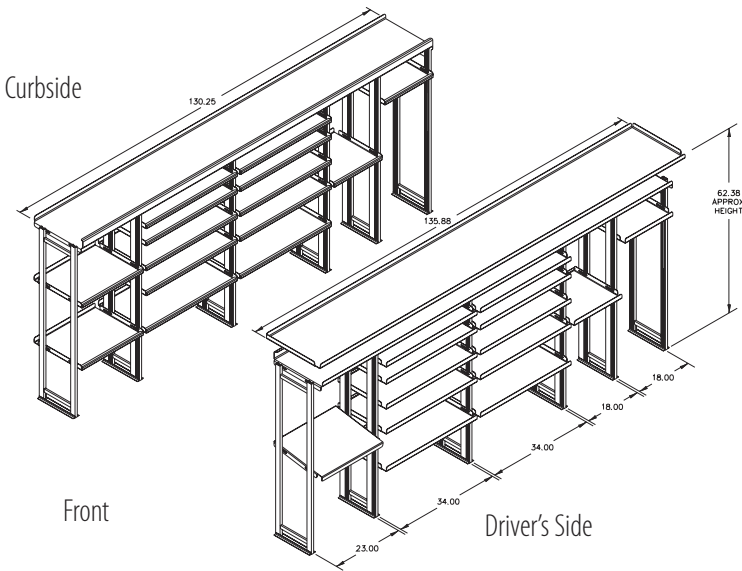

SHELVES

- (20) 34" W – adj.
- (3) 23" W – adj.
- (4) 18" W – adj.
- (2) 130" W – conduit/ladders
- (1) 136" W – conduit/ladders

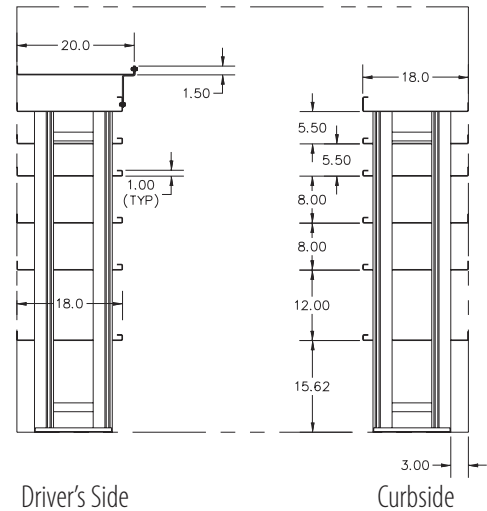

SECTION VIEW

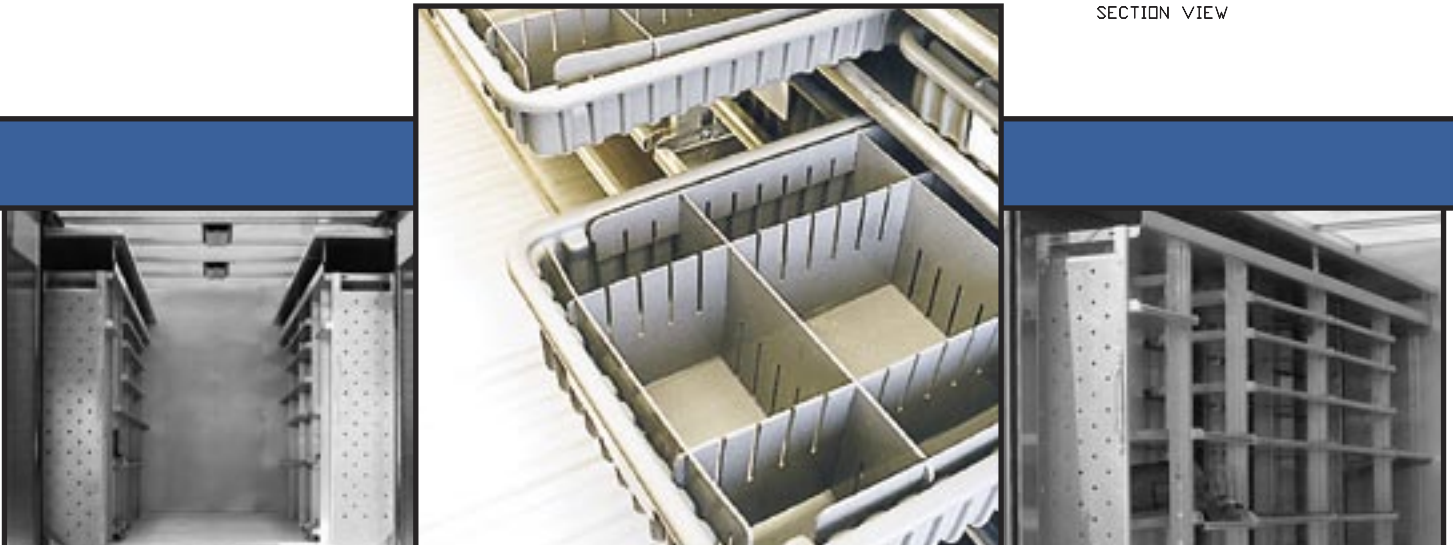

Electrical

Amp Up Business, Free Up Time

At-your-fingertips equipment and inventory make you a more time-efficient, more competitive electrical contractor. Keep your specialized ladders safely locked inside with Hackney's proven shelving system for electrical contractors. Fluorescent light tubes store easily. Shelf trays hold plastic wiring boxes and parts you need, plus there's storage for power tools, drop cords and much more.

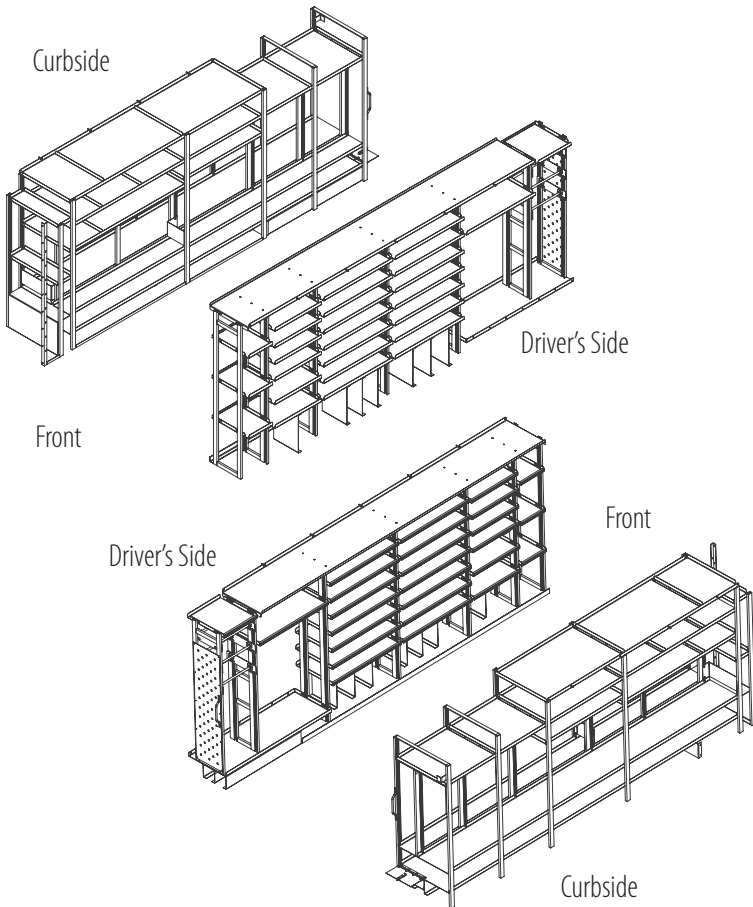

CURBSIDE

25" Shelf Depth

Ladder Storage:

24' extension + 12', 8', 6' & 4' A-frames (5 total)

Long Storage:

pipe, conduit, ground rods, fluorescent tubes (4' & 8')

Misc. Storage:

30 lineal ft. for power tools, boxes, 10 or more parts trays

DRIVER'S SIDE

18" Shelf Depth

Wire Storage:

spool rack for 8-12 rolls; vertical dividers for 10 rolls wire/cable

Bin Storage:

adjustable shelves for 50 or more plastic parts trays
20 lineal ft. Misc. Shelf Storage

Other:

perforated tool panel, mat rack, space for tool cabinet, tools, drop cords, safety equipment, supplies, quick access items

