



1-800-763-0700



# DRAIN CLEANING DC/1000 ROOTER

## STANDARD EQUIPMENT

### ROOF

Single wall aluminum

### FLOOR

Aluminum interlock panels with safety tread  
Wheel boxes in floor for lower height (Sprinter is flat floor)

### SIDES & FRONT

Double wall, aluminum exterior / white panels interior

### REAR

Aluminum step type bumper with open safety grating – 16-18" H  
Aluminum diamond plate scuff panel above bumper  
Mud flaps

### REAR DOORS

Full width double swing-out – continuous stainless steel hinges  
67.5" H x 69" W – double wall aluminum  
HD deadbolt lock with deluxe handle & push cylinder  
Spring rod door retainers to hold doors 90 degrees out

### INTERIOR SHELVES

All aluminum – 23" D, infinitely adjustable / removable, on vertical tracks  
Drivers side: Front (2) sections 36" W – 6 shelves high, Middle section 18" W – 5 shelves high, Rear section 36" W – 5 shelves high  
Curbside: Front section 36" W – 6 shelves

high, second section 23" W – 3 shelves high  
(1) full length pipe shelf at top on drivers side, (1) 72" L tool shelf at top on curbside.

### INTERIOR LIGHTS

(2) Round dome lights with switch at rear & master in cab

### PAINT

One color white to match cab

### BODY MOUNTING

Close out panel in rear of cab (5.5" cab extension on Ford)  
Remountable design



## OVERALL DIMENSIONS

Width: 80"

Length: 12 ft. (11' 6" on Ford)

Headroom: 72"

Aisle Width: ~ 31"

Height from Ground: ~ 8' 9"  
(9' 2" on Sprinter)



#09M00176

## DRAIN CLEANING - DC/1000 ROOTER

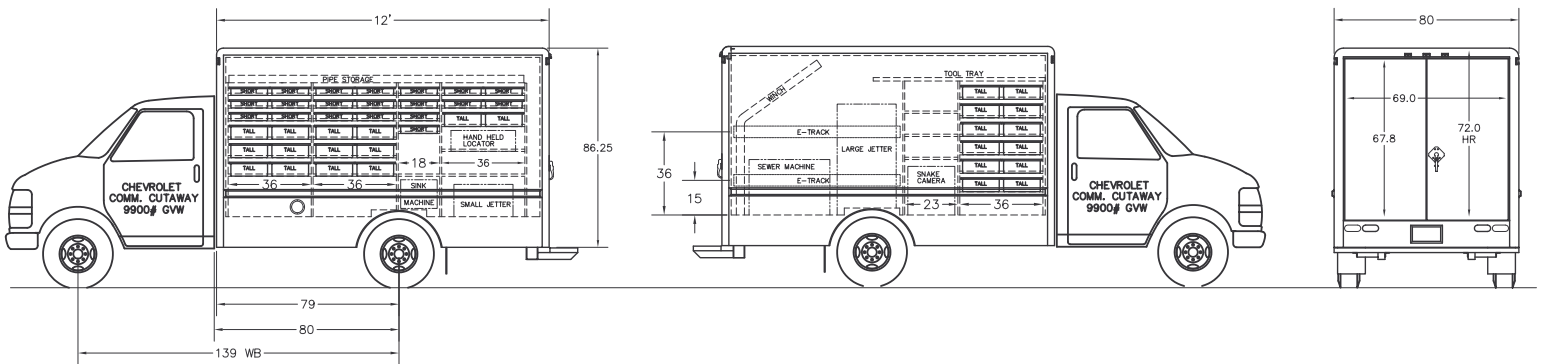

### OPTIONAL EQUIPMENT

- (2) Fluorescent Dome Lights (in lieu of std. round)
- LED Body Lights – markers, tail, brake, directional
- Translucent Roof
- (2) Salem Roof Vents
- Back Up & Door Ajar Alarm
- 8" Eyeball Cross-view Back Up Mirror
- Back Up Color Video Camera
- Velvac Exterior Cab Mirrors – extended arm (for Chev. chassis only)

- Hi-security Hockey Puck Lock for rear doors (in addition to standard)
- D.O.T. Safety Kit – FE, reflectors, flashlight
- Exterior Locking Ladder Racks – skirt mounted
- Additional Shelves – for 36" W, 23" W, 18" W sections
- HD Plastic Storage Trays – 26 Tall + 20 Short (17" x 22" – 3.5" H & 6" H) – with dividers for 9 comp. & label holders

- HD Black Felt Shelf Liners
- (2) Perforated Tool Hanging Panels – vertical end-face of shelves
- Box of (24) Tool Hanging Brackets – for rear doors
- Timbren Load Stabilizers for rear axle (for Sprinter chassis only)
- Stainless Steel Wheel Covers (for Sprinter chassis only)
- Custom Paint & Decal applications

### CHASSIS GUIDE

Cutaway Cab	Wheel Base	GVWR	Wheels
Chev. or GMC - Model G31503	139" WB	9.9K lbs.	Single Rear
Ford - Model E350	138" WB	9.9K lbs.	Single Rear
Sprinter - Model 3500C	144" WB	11.03K lbs.	Dual Rear

Hackney reserves the right to make changes on standard and optional equipment at any time without prior notice. All available options and standards are not listed. Since chassis specifications can change at any time, Hackney can not guarantee that these wheelbase body combinations will be compatible.

### HACKNEY SERVICE VEHICLES

400 Hackney Avenue  
 Washington, NC 27889  
 1-800-763-0700  
 1-252-946-6521  
 Fax 1-252-975-8340



www.hackneyservice.com



## DRAIN CLEANING - DC/2000

### STANDARD EQUIPMENT

#### ROOF

Double wall with insulation, aluminum exterior / white panels interior

#### FLOOR

Aluminum interlock panels with safety tread

#### SIDES & FRONT

Double wall, aluminum exterior / white panels interior

#### REAR

Aluminum step type rear bumper with open safety grating

Aluminum diamond plate scuff panel above bumper

Cast aluminum recessed license plate holder with light

Mud flaps

#### REAR DOORS

Full width double swing-out – 79" H x 73" W – double wall aluminum

HD deadbolt lock with deluxe handle & push cylinder

Spring rod door retainers to hold doors 90 degrees out

#### INTERIOR SHELVES

All aluminum – 18" D, infinitely adjustable / removable, on vertical tracks

23" W section front – 2 shelves high CS & 3 shelves high DS

(2) 34" W sections middle – 4 shelves high CS & 5 shelves high DS (total 18)

18" W section – 2 shelves high CS & 3 shelves high DS

Open space under middle shelves CS – 53" W x 31" H

23" W section rear – 2 shelves high CS & DS

Fixed full length pipe & ladder shelves above adjustable shelves each side (total 4)

#### INTERIOR LIGHTS

(3) Round clear overhead dome lights with switch at rear & master over-ride in cab

#### PAINT

One color white to match cab

#### CHASSIS ALTERATION & MOUNTING

Drop frame behind rear axle for lower rear entrance, walk-in access

### OVERALL DIMENSIONS

**Width:** 84" (90" Optional)

**Length:** 12' 6" (14' & 16' optional)

**Headroom:** 75"

**Aisle Width:** ~ 45"

**Height from Ground:** ~ 9' 4" diesel / ~ 9' 6" gas (loaded)





# DRAIN CLEANING- DC/2000

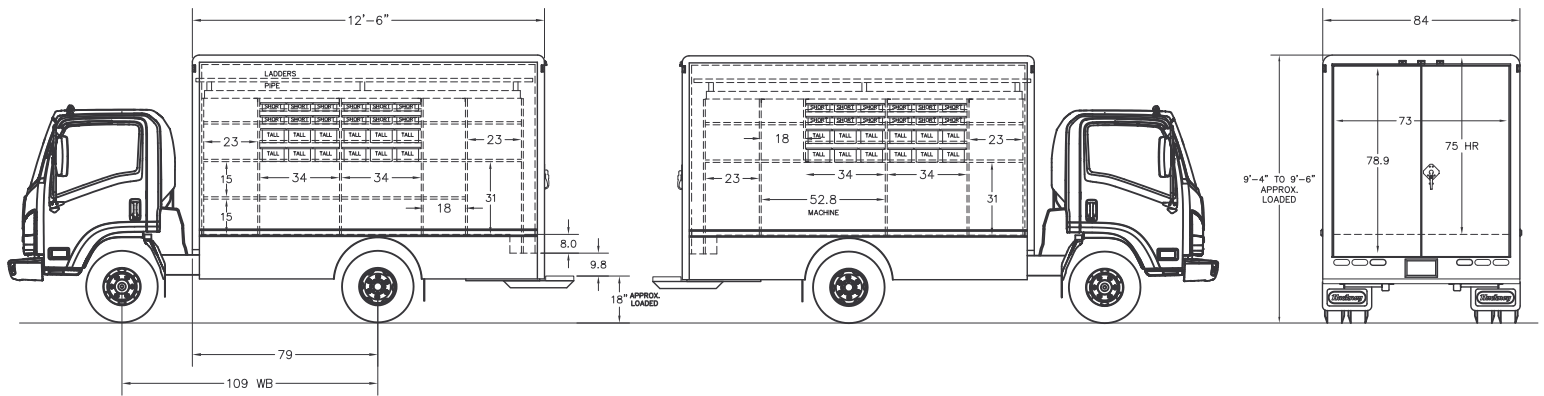

## OPTIONAL EQUIPMENT

- Extended Body Length – 14 ft. & 16ft. (16 ft. n/a with Sprinter or Cutaway)
- 90" Body Width (required with some chassis)
- (3) Fluorescent Dome Lights (in lieu of std. round)
- LED Body Lights – markers, tail, brake, directional
- Translucent Roof – no insulation
- (2) Salem Roof Vents
- Back Up & Door Ajar Alarm
- 8" Eyeball Cross-view Back Up Mirror
- Back Up Color Video Camera
- D.O.T. Safety Kit – FE, reflectors, flashlight
- Class III Receiver Hitch with wiring & drawbar

- Class III Receiver Hitch w/o wiring & drawbar (Sprinter only)
- Pull-out Ramp under floor – 9' 6" L x 24.5" inside W
- Pipe Compartment under floor (in lieu of ramp)
- Skirt Storage Compartments
- Hi-security Hockey Puck Lock for rear doors (in addition to standard)
- Exterior Swing-out Pipe / Ladder Racks – skirt mounted
- Exterior Locking Ladder Racks – skirt mounted
- Additional Shelves – for 34" W, 23" W, or 18" W sections
- Set of Orbis / Lewis Plastic Storage Trays

- 24 Tall + 24 Short (11" W x 17" L– 3.5" H & 6" H) – with dividers & label holders
- HD Black Felt Shelf Liners
- Perforated Tool Hanging Panels – end of shelves by doors
- Tool Hanging Brackets – for rear doors
- Pipe Vise Receiver and Mounting Plate – Rear Bumper
- Velvac Exterior Cab Mirrors – extended arm (for Chev. chassis only)
- Timbren Load Stabilizers for rear axle (for Sprinter chassis only)
- Stainless Steel Wheel Covers
- Custom Paint & Decal applications

## CHASSIS GUIDE

Low Cab Forward	Rating GVWR	Wheelbase
Isuzu NPR (Gas or Diesel)	12K lbs. to 14.5K lbs.	109" WB – 86.5" CA -12' 6" Body
		132.5" WB – 110" CA -14' Body
		150" WB – 127.5" CA -16' Body
CV Conventional Cab	Rating GVWR	Wheelbase
Ford F-450 / F-550 (Gas or Diesel)	16K lbs. to 19K lbs.	164.8 WB – 84" CA -12' 6" Body
		188.8 WB – 108" CA -14' Body
		200.8 WB – 120" CA -16' Body
Cutaway Cab	Rating GVWR	Wheelbase
Chev. or GMC "G" Model DRW (Gas or Diesel)	12K lbs. to 14.5K lbs.	139" WB – 12' 6" Body
		159" WB – 14' Body

## HACKNEY SERVICE VEHICLES

911 West 5th Street  
 Washington, NC 27889  
 1-800-763-0700  
 1-252-946-6521  
 Fax 1-252-975-8340

Hackney reserves the right to make changes on standard and optional equipment at any time without prior notice. All available options and standards are not listed. Since chassis specifications can change at any time, Hackney can not guarantee that these wheelbase body combinations will be compatible.

\* Additional chassis models available. Visit [hackneyservice.com](http://hackneyservice.com) for more information.



[www.hackneyservice.com](http://www.hackneyservice.com)



# HACKNEY RESTORATION

## THE WORLD'S SMARTEST SERVICE BODIES LOADED WITH FEATURES

### DEFINING PROFESSIONAL

Hackney Performer bodies have been a mainstay in the plumbing, electrical, and HVAC markets for over 15 years, but the all-aluminum work truck will now make its presence in the cleaning and restoration industry.

Hackney bodies have a history of delivering value to operators by maximizing the storage and efficiency inside, while providing a durable body that is re-mountable and can serve over 20 years.

Designed by operators, Hackney's custom shelving organizes equipment such as air movers, dehumidifiers, and extractors, while providing additional storage for tools and bin trays. The swing out curbside door provides quick access to vacuum, airline, and water hose reels. Additional options such as a driver side service compartment and rear pull-out ramp are also available. The Performer features smooth side walls for graphics to provide a great outlet for advertising.

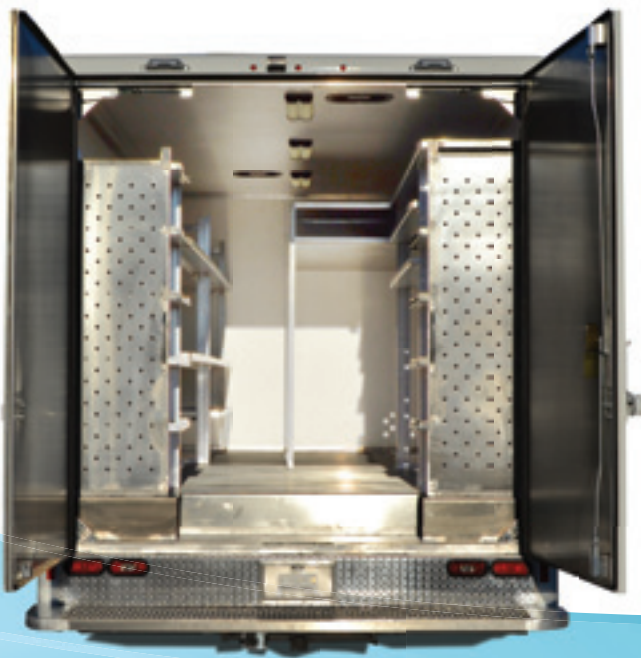

# HACKNEY RESTORATION UNIQUE FEATURES



## LARGE SWING-OUT CURBSIDE DOOR

Gain quick access to vacuum, airline and water hose reels.

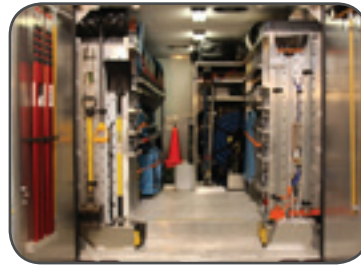

## GET ORGANIZED

Hackney's C&R custom specific shelving allows you to organize all your equipment for the job and increase job site efficiency.



## MAXIMIZED DRIVER SIDE STORAGE

Hackney's shelving system provides ample room for dehumidifiers and air movers to be securely transported, while providing small part trays and tool storage.



## SMART CURB SIDE STORAGE

Hose reels, extractor and tank are positioned in the front for side door access, while additional custom shelving is provided in rear for tool and parts storage.

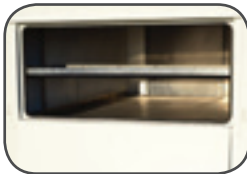

## DRIVER SIDE SERVICE COMPARTMENT

Optional drop down service compartment provides quick and easy driver access to daily tools. Trays can be provided for optimal organization.



## ALL ALUMINUM BODY

Lighter weight means more payload; natural resistance to corrosion; easier to repair; longer service life; highly recyclable.



## REMOUNTABLE BODY

All Hackney bodies are designed to be remounted when the chassis wears out, with extra strength where it counts for multiple swaps to new chassis.



## DROP FLOOR AND CHASSIS FRAME

The chassis frame and the body floor is dropped behind the rear axle creating a lowered, full width, recessed rear stepwell for walk-in access to the interior.



## HEAVY DUTY CORNER POST & TOP RAILS WITH CAST CORNER CAPS

Extruded aluminum corner post and top rails for extra strength and smoother appearance. Cast aluminum corner caps welded in place and finished off for seamless appearance and maximum rigidity.



## HEAVY GAUGE ONE PIECE SIDE PANELS

Single sheet .125 gauge aluminum with only perimeter rivets showing. Side panels are bonded to intermediate body posts to achieve the smooth billboard sides for impact graphic presentation.

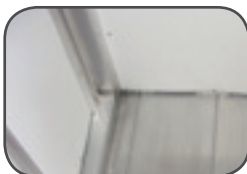

## DOUBLE WALL CONSTRUCTION

Front bulkheads and rear doors are double wall on all models for added strength and protection from everyday abuse. Models have double wall side panels as well, with aluminum exterior and white Roofs are double wall with insulation.



## DROPPED SKIRTS

All Hackney bodies have lowered skirts that flush out with chassis cabs to give a sleek, modern, low profile look. Lowered skirts also hide batteries, fuel tanks, and other chassis components for a cleaner appearance.



## BATTERY & FUEL ACCESS DOORS

Maintains the unbroken smooth look of the body exterior, yet allows full access to these chassis components.

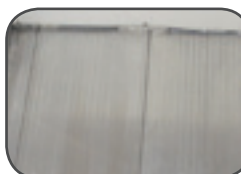

## ALUMINUM SNAP-TOGETHER FLOOR PLANKS

Structural floor planks are extruded from one piece of aluminum, with floor reinforcement ribs and locking grooves formed in place. Joined together and welded, they form an exceptionally strong floor assembly with low clearance over the frame.

HACKNEY SERVICE VEHICLES 911 West 5th Street, Washington, NC 27889

1-800-763-0700 1-252-946-6521 Fax-1-252-975-8340

**Hackney**

[www.hackneyrestoration.com](http://www.hackneyrestoration.com)